



**General Description:**

DCS 400 Series modules increase the ProAnnounce system's control capabilities in many ways. The DCS system can be expanded at any time after installation for increased functionality. The DCS control system consists of the following components:

- DCS 400 main module chassis
- DCS 401R primary system control module.
- DCS 405R extension module.
- DCS 408R relay module.
- DCS 409R relay module.
- DCS 412R logic input module.
- DCS 416R analog I/O module.
- DCS 420 monitor unit.

The ProAnnounce operating system defines the total amount of supported control inputs and outputs. A ProAnnounce installation allows integrating a maximum of up to 8 DCS 401R control modules. A single control module can host up to 12 relay boards of the types DCS 408R / DCS 409R in any sequence. In addition, it is possible to connect up to 5 logic input modules, 2 analog I/O modules, and 2 rotary encoders. In total, the ProAnnounce system can manage up to following amounts of different DCS cards:

- 8 DCS 401R control modules.
- 48 DCS 408 / DCS 409 relay modules.
- 10 DCS 412 logic input module.
- 8 DCS 416 Analog I/O module
- 1 DCS420 Monitor Unit

**DCS 400 19" RACK FRAME**

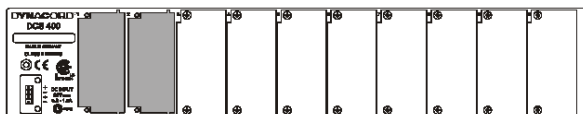

The DCS 400 is a 19" base unit with a height of 2 HU. It can host a control module as well as several relay modules, logic input modules, and analog I/O modules that are connected via internal backplane.

- 10 slots for the insertion of DCS modules.

- 4 position Phoenix type connector for power supply.
- 2 LED's on the front indicating power.
- Internal backplane with system bus.
- Internal self-resetting fuses.

**DCS 401R CONTROL MODULE**

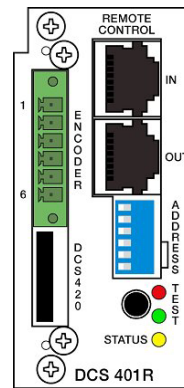

The module represents the interface for relay boards, logic boards, analog level I/O-boards, a monitor module, and rotary encoders. It is inserted into slot 1 (the slot all the way on the left) on the rear of the DCS 400 rack frame. It is controlled from the DPM 4000 via RS-485 remote interface. Maximally 12 relay modules (DCS 408R / DCS 409R / DCS 408 / DCS 409), 5 logic input modules (DCS 412R, DCS 412), 2 analog I/O modules (DCS 416R / DCS 416), 2 rotary encoders and 1

monitor module DCS 420 can be connected to a single DCS 401R control module.

- Two RJ-45 sockets for connecting the DPM 4000 and cascading several DCS 401R or DCS 401 modules.
- Galvanic isolated RS-485 port.
- Connector for 2 rotary encoders.
- Connector for DCS 420 monitor module.
- Monitoring via watchdog circuitry.
- Service-functions and testing-software for all connected modules.
- 6 binary switches for setting addresses and selecting service-functions
- 1 pen-tip pushbutton – test start.
- 3 LED's - red, yellow, green for test mode and status.
- A maximum amount of 8 modules DCS 401R or DCS 401 can be cascaded.

**Specifications:**

Operating voltage 24 V DC, -10 / +30%  
 Operating current 25 mA to 65 mA  
 Operating current at 24 V 35 mA  
 Operating temperature range +5° C to +40° C  
 Dimensions (W x H x D) 37.5 x 80.6 x 245 mm  
 Weight 207 g

## DCS 405R EXTENSION MODULE

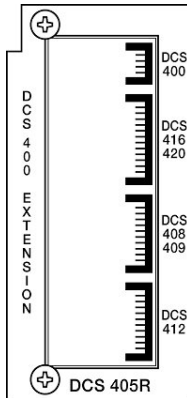

The module is used to provide connection to another DCS 400 rack frame and /or other DCS 400 boards. This is useful in situations where there are more cards on a given DCS 401R than a single DCS 400 frame can support.

### Installation Notes

In the first DCS 400 rack frame the DCS 405R extension module always needs to be installed in the first empty slot (the slot right of any other modules installed). In the

DCS 400 extension unit – the second unit installed – the DCS 405R extension module always needs to be installed in slot 1 (the slot all the way on the left, instead of the DCS 401R).

### Specifications:

Operating temperature range +5° C to +40° C  
Dimensions (W x H x D) 37.5 x 80.6 x 245 mm  
Weight 115 g

## DCS 406R SHIELDING MODULE

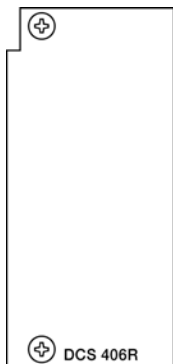

The module is meant for insertion on the rear of the DCS 400 rack frame providing shielding between DCS 408R and DCS 409R modules.

### Specifications:

Dimensions (W x H x D) 37.5 x 80.6 x 245 mm  
Weight 71 g

## DCS 407R CONTROL RELAY MODULE

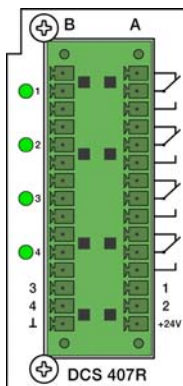

The module provides switching for audio signals (line level) or control outputs independent from the DCS 400 system.

- 4 LF-relays, each with 2 SPDT switching contacts.
- Gold-plated double-contacts for improved contact.
- Phoenix type connector for all contacts and coils.
- 4 relay control-LED's.
- Configuring the audio distributor is possible through separating wire-

bridges.

- Switchable monitor bus link.

### Specifications:

Operating voltage 24V DC, -10% / +30%  
Operating current, all relays on 37 to 54 mA  
Operating current, all relays on at 24 V 42 mA  
Operating temperature range +5° C to +40° C  
Dimensions (W x H x D) 37.5 x 80.6 x 245 mm  
Weight 163 g

### Relay Contacts:

Contacts DPDT  
Contact material AgPd + 10μ Au  
Contact load (real) 1A / 24V DC, 0.5A / 120V AC  
Contact current max. 2A

## DCS 408R / 409R CONTROL RELAY MODULES

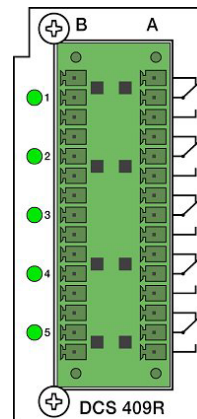

These modules provide relay contact closures for use in switching audio or other control functions. The 408R is capable of switching of 70v or 100V speaker lines. The 409R is capable of switching line level audio signals or control outputs. The 408R can also be used to provide contact closures where higher voltages and/or current may be involved.

- 5 line relays, each with 2 switching contacts.
- Phoenix type connector for all contacts.
- 5 relay control-LED's.
- Configuring the signal distributor is possible through separating wire-bridges.
- 12 DCS relay modules can be cascaded.

### Specifications:

Operating voltage 24V DC, -10% / +30%  
Operating current, relays off 5.2 mA to 7.8 mA  
Operating current, relays off at 24 V 5.5 mA  
Operating current, all relays on 55-130 mA  
Operating current, all relays on at 24 V 60-96 mA  
Operating temperature range +5° C to +40° C  
Dimensions (W x H x D) 37.5 x 80.6 x 245 mm  
Weight 225 g

### Relay Contacts:

Contacts DPDT  
Contact material AgNi 90/10  
Contact load (real) 408R-2000 VA, 409R-1A

## DCS 412R LOGIC INPUT MODULE

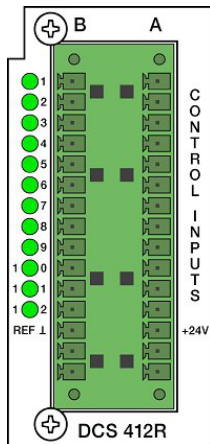

The module provides inputs for control lines, pushbuttons, switches, and sensors, allowing the evaluation of their individual status (ON / OFF) in the DPM 4000 system.

- 12 inputs.
- Selectable polarity of each input.
- Floating inputs can be realized via the separation of wire bridges.
- Separate connections for power supplies of pushbuttons, contacts and sensors.

- Phoenix type connector for all inputs.
- Maximally 5 DCS412R / DCS412 modules can be cascaded.

### Specifications:

Operating voltage 24V DC, -10 / +30%  
 Operating current, all inputs open 2.6 mA to 8.2 mA  
 Operating current, all inputs at 24V 60 mA to 83 mA  
 Operating temperature range +5° C to +40°C  
 Dimensions (W x H x D) 37.5 x 80.6 x 245 mm  
 Weight 175 g

### Input Level:

Input voltage for off (Low)  $U_{IN} < \pm 5$  V  
 Input voltage for on (High)  $U_{IN} > \pm 10$  V  
 Input current at  $U_{IN} = 24$  V  $I_{IN} = 4.8$  mA  
 Input voltage max.  $U_{IN\ max} = \pm 31$  V  
 Output source voltage 24V DC  
 Output source current max. 90 mA

## DCS 416R ANALOG I/O MODULE

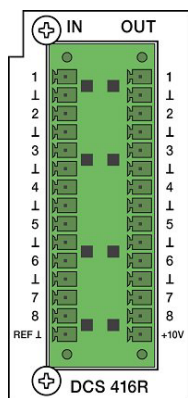

The module provides analog input and output interfacing capabilities for use in monitoring and control functions. Both inputs and outputs are capable of handling 0 to 10V DC with 256 distinct levels. Potentiometers for volume control can be interfaced using the provided reference voltage output.

- 8 analog inputs.
  - Voltages of 0 to 10V DC or a potentiometer to each input.
  - Output for reference voltage 10V DC.
- 8 analog outputs 0 to 10V DC.
  - Phoenix type connector for all inputs and outputs.
  - Maximally 2 DCS 416R / DCS 416 modules can be cascaded.

### Specifications:

Operating voltage 24V DC, -10 / +30%  
 Operating current (max.) 160 mA  
 Operating temperature range +5° C to +40°C  
 Dimensions (W x H x D) 37.5 x 80.6 x 245 mm  
 Weight 170 g

### Inputs:

Voltage range (min. to max.) 0 V to 10 V DC  
 Impedance range ext. (min. to max.) 0 to 10 kOhm  
 Maximum input voltage 50 V DC

### Outputs:

Voltage range (min. to max.) 0 V to 10 V DC  
 Output impedance 47 Ohm  
 Maximum load 2k Ohm  
 Resolution of Inputs / Outputs 8 Bit  
 Reference output voltage 10 V DC  
 Reference output current 30 mA (max.)

## DCS 420 MONITOR STATION



The DCS 420 Monitor Manager is a 2RU unit offering acoustic control and visual level metering of audio in the system. Switching and displaying of up to 250 audio signal sources, as well as, controlling the volume is carried out via front panel control switches.

THE DCS420 receives its audio feed from the monitor output of the DPM4000. DCS420 system control functions are carried out through a connection to the DCS401 controller module. The front panel controls of the DCS420 offer audio level and line control switching of either the input signal or the output signal of the system amplifiers.

With several external sound sources connected, switching is performed through the DCS 409R module. When using remote-amplifiers, switching audio signals to the monitor bus is accomplished directly inside the amplifier. The signals are transmitted via remote interconnection cables

## Architecture & Engineering Specifications:

The expansion system is designed for use with the ProAnnounce system and shall enable the use of a variety of system control and output routing devices. The system shall consist of a 2RU system rack frame accommodating any one of a series of 6 expansion control modules, which slide in the rear of the unit. The rack frame shall hold up to 10 expansion cards. It shall be powered from a 24V DC source supply through a dual spade lug terminal connection. The system shall be equipped with internal self-resetting fuses. The system shall enable the use of analog or digital controls; expand the system operation to include relay operated switching and remote monitoring. The system shall also offer the ability to add a rack mounted monitor unit for in place control and monitoring of any channel.

The expansion system shall be the Dynacord ProAnnounce DCS digital control system.

## Available Accessories:

Model	Cat. No.	Description
NRS90240	121742	Volume Shaft Encoder

## Ordering Information:

Model	Cat. No.	Description
DCS420	121753	Monitoring Unit
DCS400	121773	19" Frame for DCS Modules
DCS401R	121774	Controller Module
DCS405R	121775	Extension Module
DCS406R	121776	Shield Module
DCS407R	121777	AF-Relay Module w/Ext Control
DCS408R	121778	Lines-Relay Module
DCS409R	121779	AF-Relay Module
DCS412R	121780	Logic Input Module
DCS416R	121782	Analog I/O Module

## Block Diagrams:

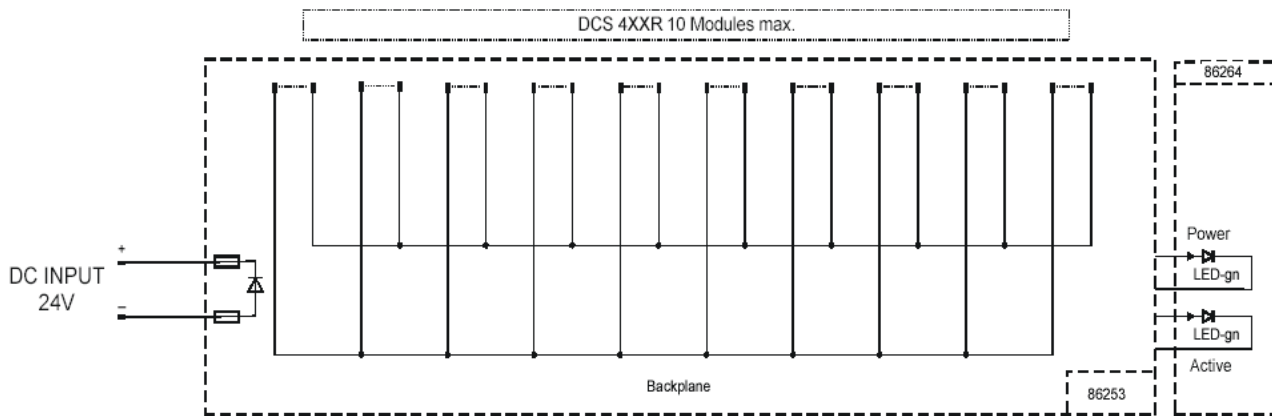

Rack Frame  
**DCS 400**  
 BLOCK DIAGRAM

# Block Diagrams:

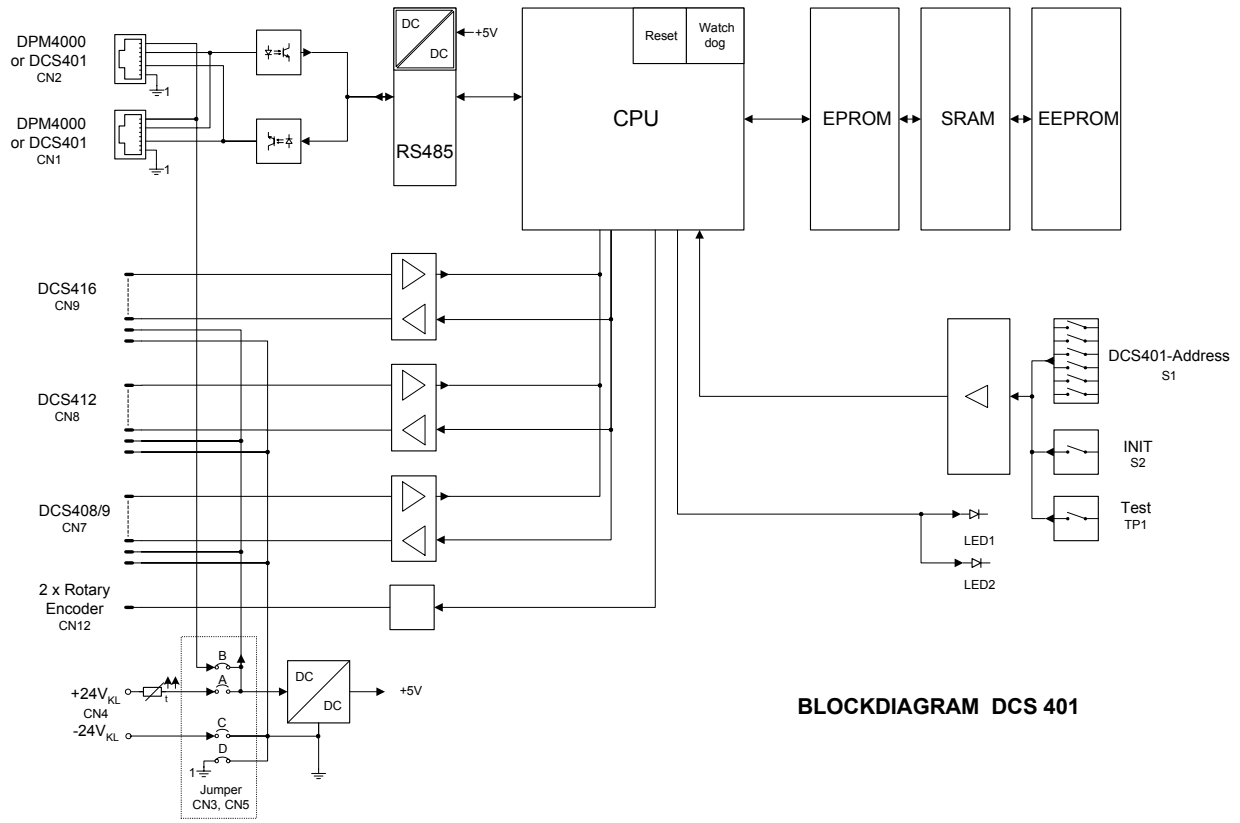

**BLOCKDIAGRAM DCS 401**

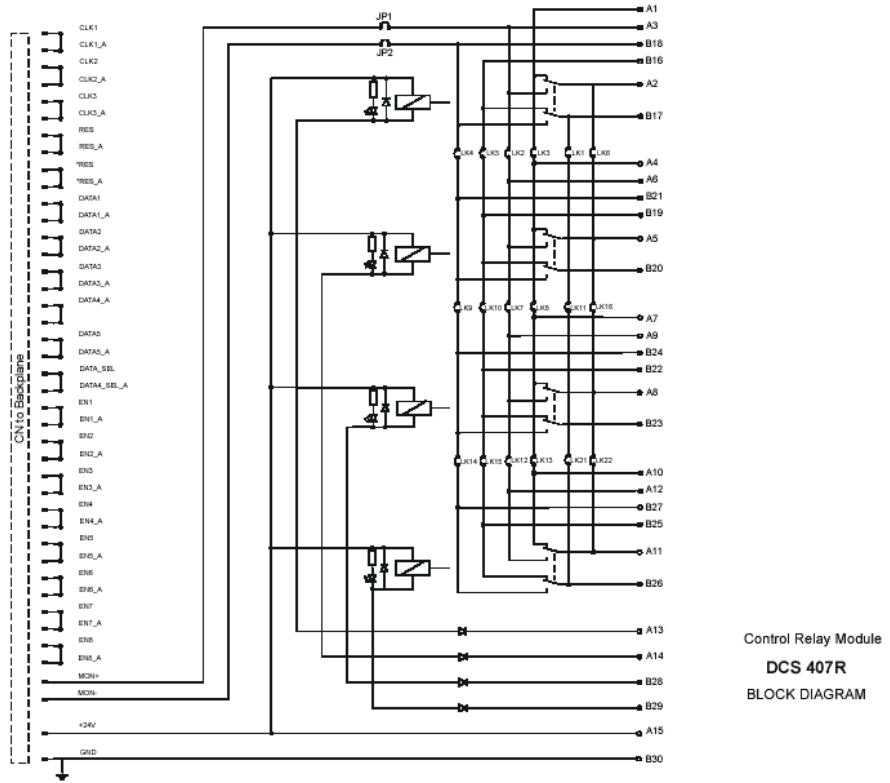

**Control Relay Module  
DCS 407R  
BLOCK DIAGRAM**

# Block Diagrams:

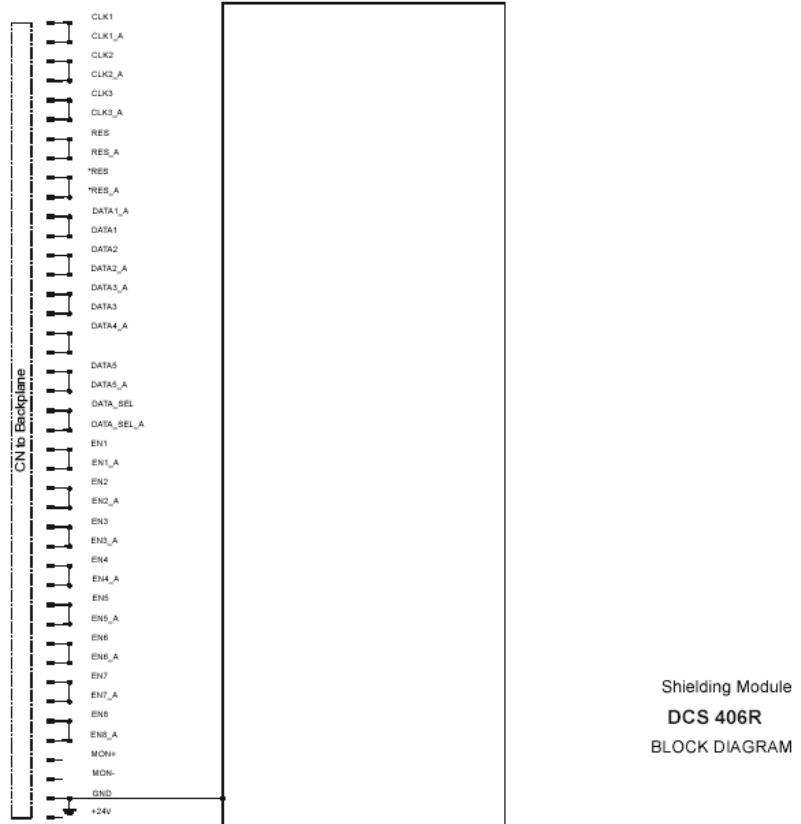
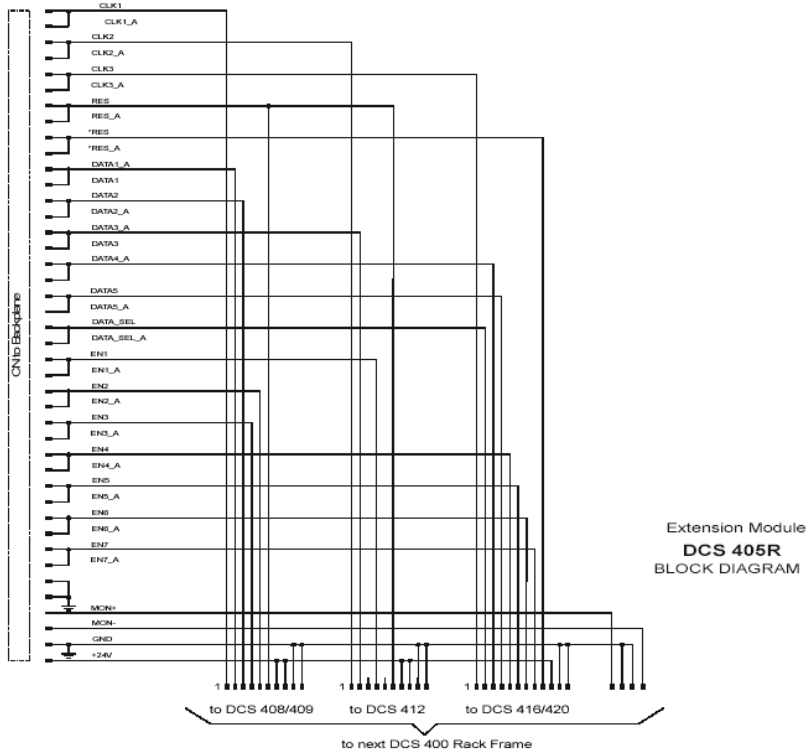

# Block Diagrams:

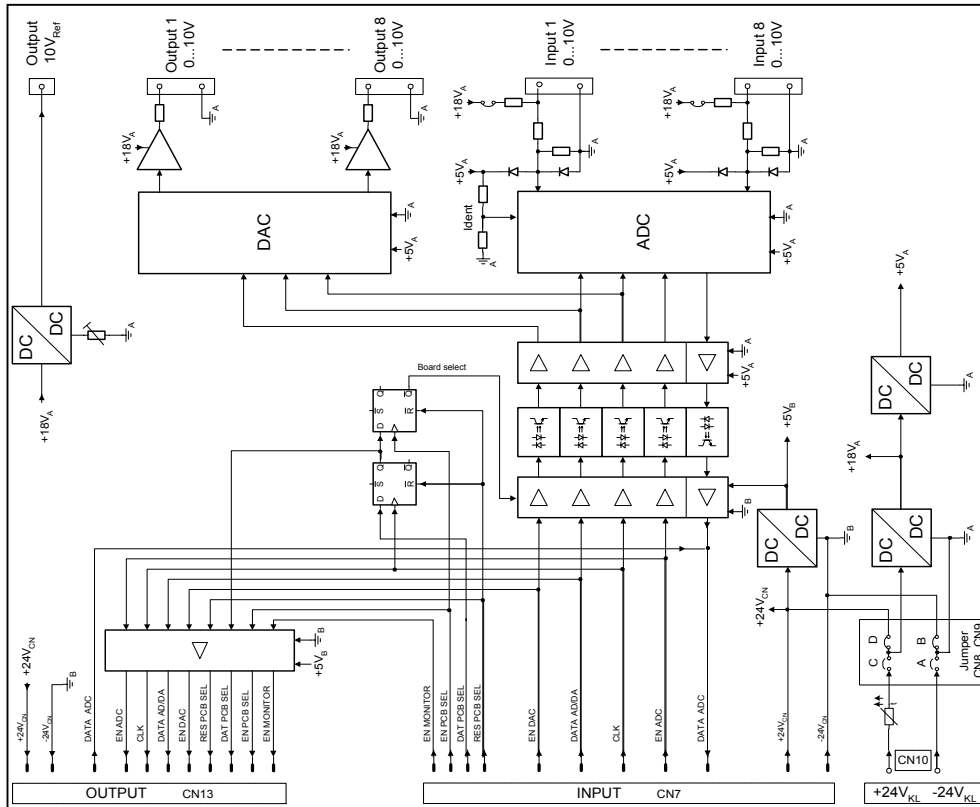
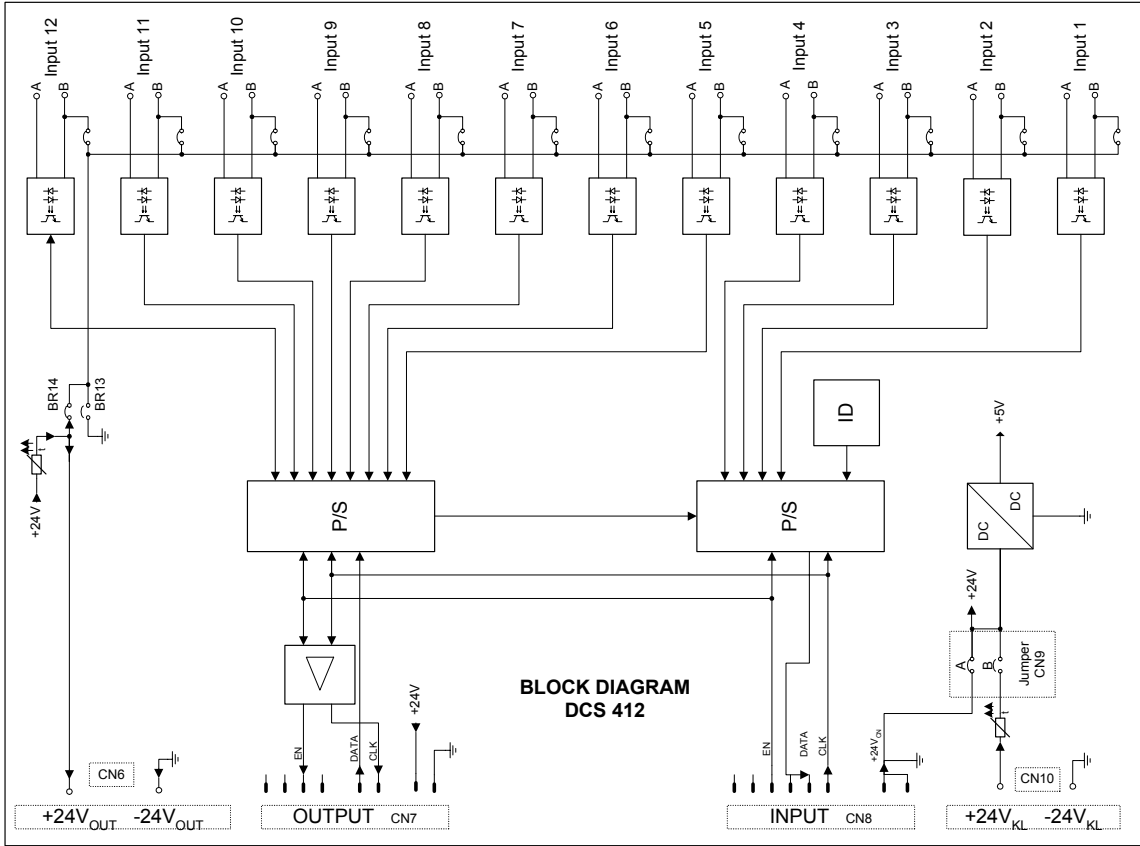

# Block Diagrams:

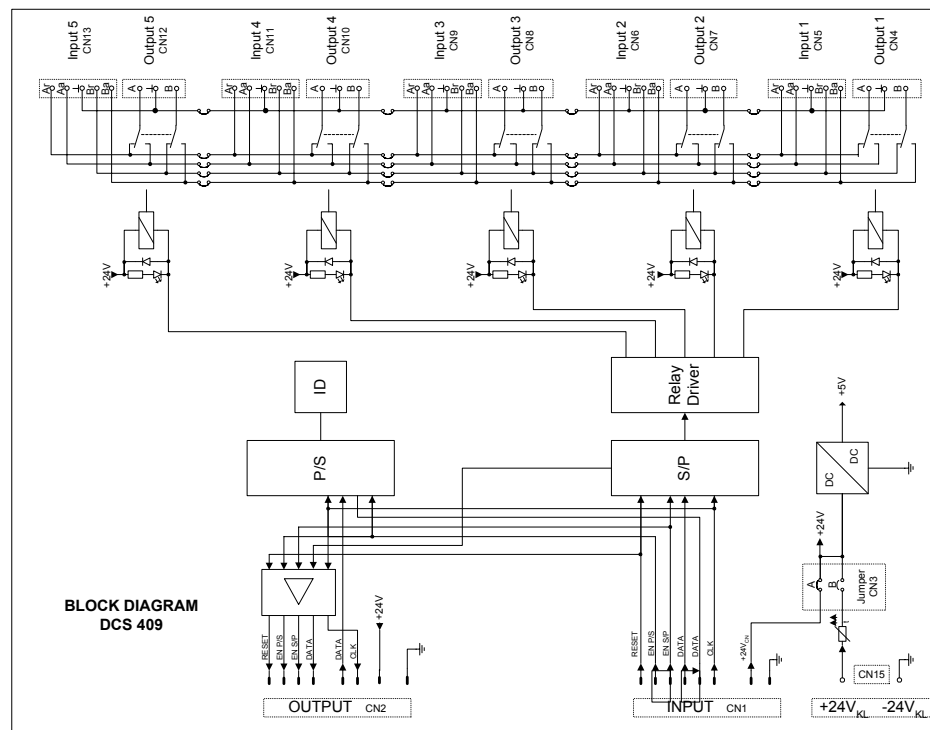
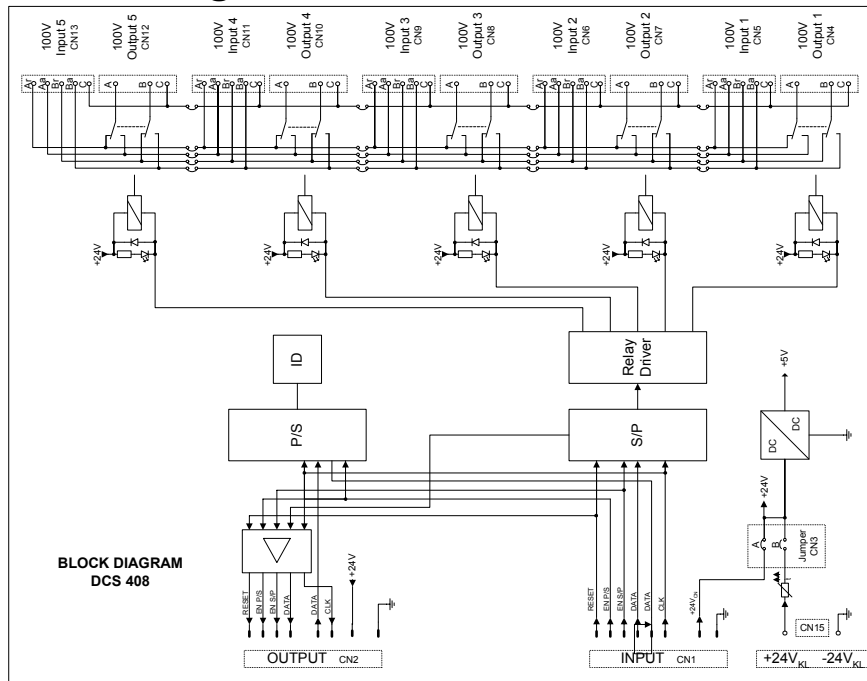

**EV Electro-Voice®**  
 12000 Portland Av. South, Burnsville, MN 55337  
 Phone: 952-887-4051, Fax: 952-887-0043  
[www.electrovoice.com](http://www.electrovoice.com)  
 Telex Communications Inc 11/2002  
 Part Number 38109-xxx Rev A

USA and Canada Only. For customer orders contact  
 Customer Service at: 800/392-3497 Fax: 800/955-6831